

# AC/DC VOLTAGE SENSOR & AC CURRENT SENSOR

Type **TMS**

RAIL VEHICLES



# GENERAL INFORMATION

Sécheron **TMS** is a medium voltage and current measuring sensor dedicated to rolling stock applications. It is used to deliver voltage and current signals to various on-board equipment such as energy meter, converter control units, vehicle control unit and vehicle protection devices. Its voltage detection capability allows the TMS to identify any AC or DC line voltage and transmit this information to the Train Control and Management System (TCMS).

**TMS** measures any AC or DC line supply voltage and transmits safe isolated and accurate signals class 0,5 R. When delivered with the current measurement function, TMS also measures the vehicle AC input current with an accuracy class 0,5 R for the on-board energy measurement or class 0,5 for other on-board functions. TMS complies with EN 50463-2/IEC 62888-2 standards for on-board energy measurement and with IEC 61869-2 for other applications

## APPLICATIONS, TYPICAL EXAMPLE

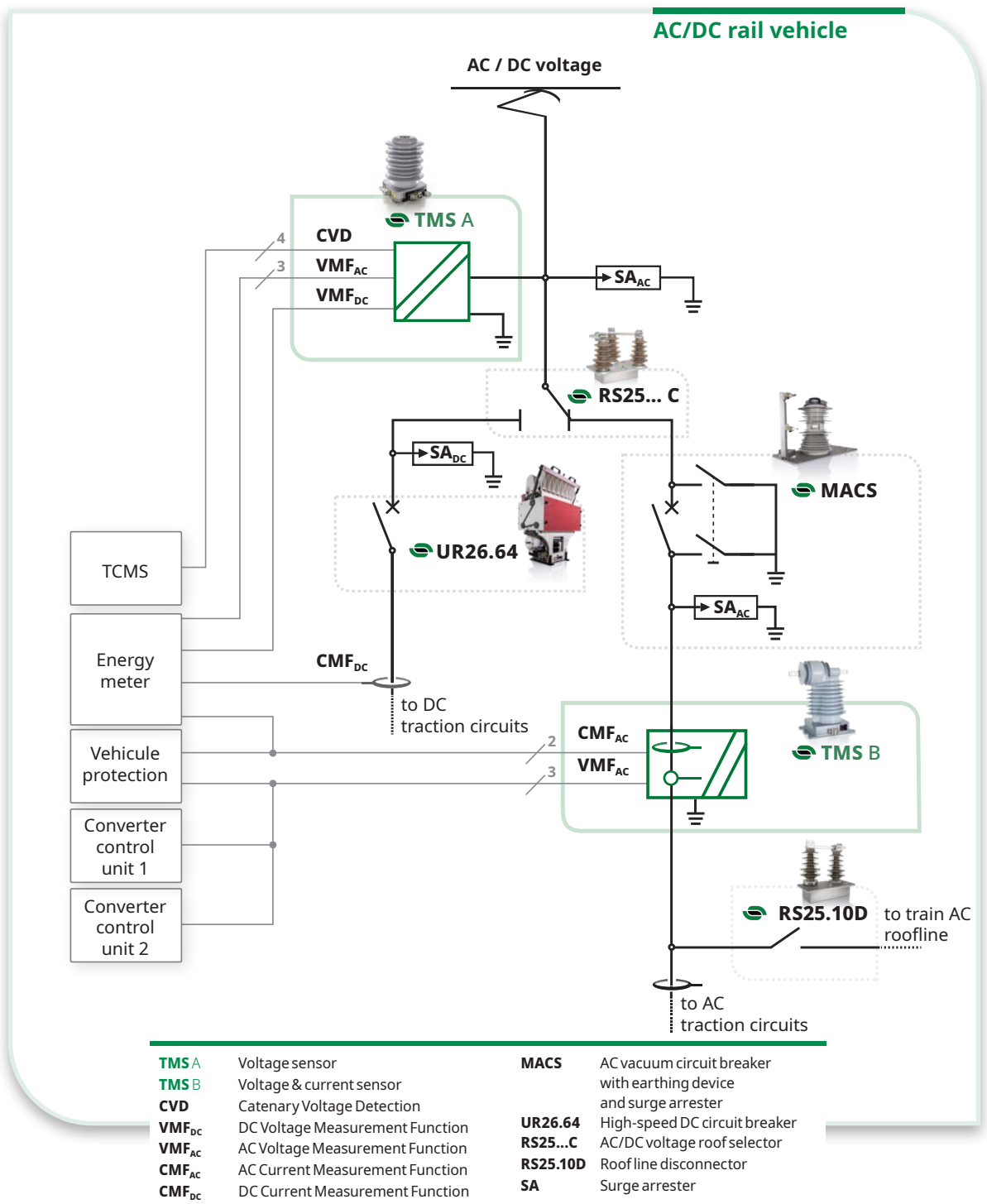

## AC/DC typical application

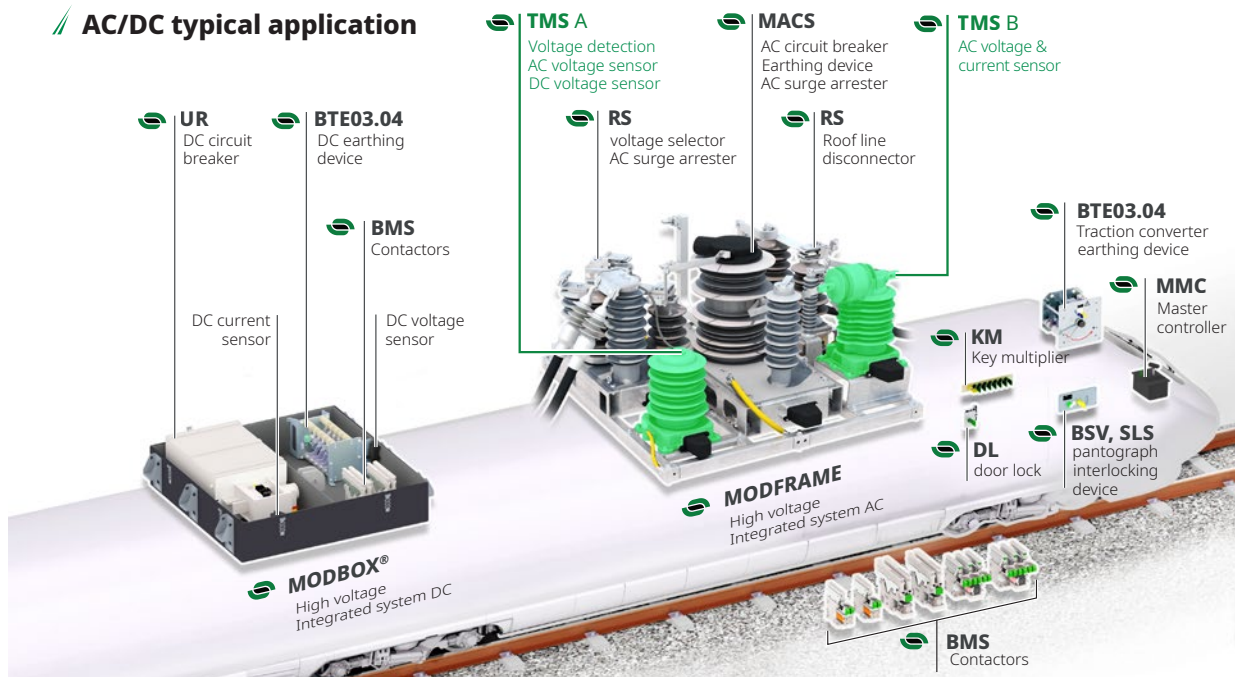

## MAIN FEATURES

- Measurement of any AC catenary voltage between 15 kV and 25 kV with frequency between 16.7 and 60 Hz. Measuring line voltages lower than 15 kV are also possible on request.
- Measurement of any DC catenary voltage between 750 V and 3 kV
- Measurement of vehicle input current from 100 A to 630 A (15 kV<sub>AC</sub>) and from 60 A to 400 A (25 kV<sub>AC</sub>). Other values on request.
- Catenary voltage detection function
- Insulation voltage 31.5 kV<sub>AC</sub>.
- Impulse withstand voltage 170 kV.
- Suitable for indoor or outdoor installation.
- Suitable for energy measurement function (accuracy class 0,5 R) or other applications
- 1 or 3 outputs for AC voltage measurement
- 1 output for DC voltage measurement.
- 1 or 2 outputs for AC current measurement.
- 4 digital outputs for Catenary Voltage Detection.
- Reference standards:  
EN 50463-2/ IEC 62888-2, IEC 61869-2,  
EN/IEC 60044-7, EN 50124-1/ IEC 62497-1,  
EN/IEC 61373, EN 50155, EN 45545-2.

## MAIN BENEFITS

- ✓ Certified TSI Loc&Pas according to EN 50463-2.
- ✓ Multifunctional and multi-application device.
- ✓ Specific version dedicated only to energy measurement.
- ✓ No delay between input and output signals.
- ✓ Suitable for traction control and protection.
- ✓ Current loop transmission for noise immunity.
- ✓ Insulated outputs.
- ✓ Outputs compatible with Sécheron MACS AC circuit breaker for switching synchronization and protection functions.
- ✓ AC Voltage measurement output signals with optional offset for safety critical applications.
- ✓ Simple electronic architecture without embedded software.
- ✓ Inductive technology for current measurements.
- ✓ Compact & lightweight.
- ✓ Safe against internal arcs.
- ✓ Horizontal or vertical mounting.
- ✓ Thoroughly tested, including life time aging tests .
- ✓ Sécheron high expertise in AC & DC medium voltage components and systems.
- ✓ Can also be delivered integrated in Sécheron's medium voltage integrated systems MODBOX and MODFRAME.

# PRODUCT STRUCTURE & FUNCTIONAL SCHEME

TMS B

TMS A

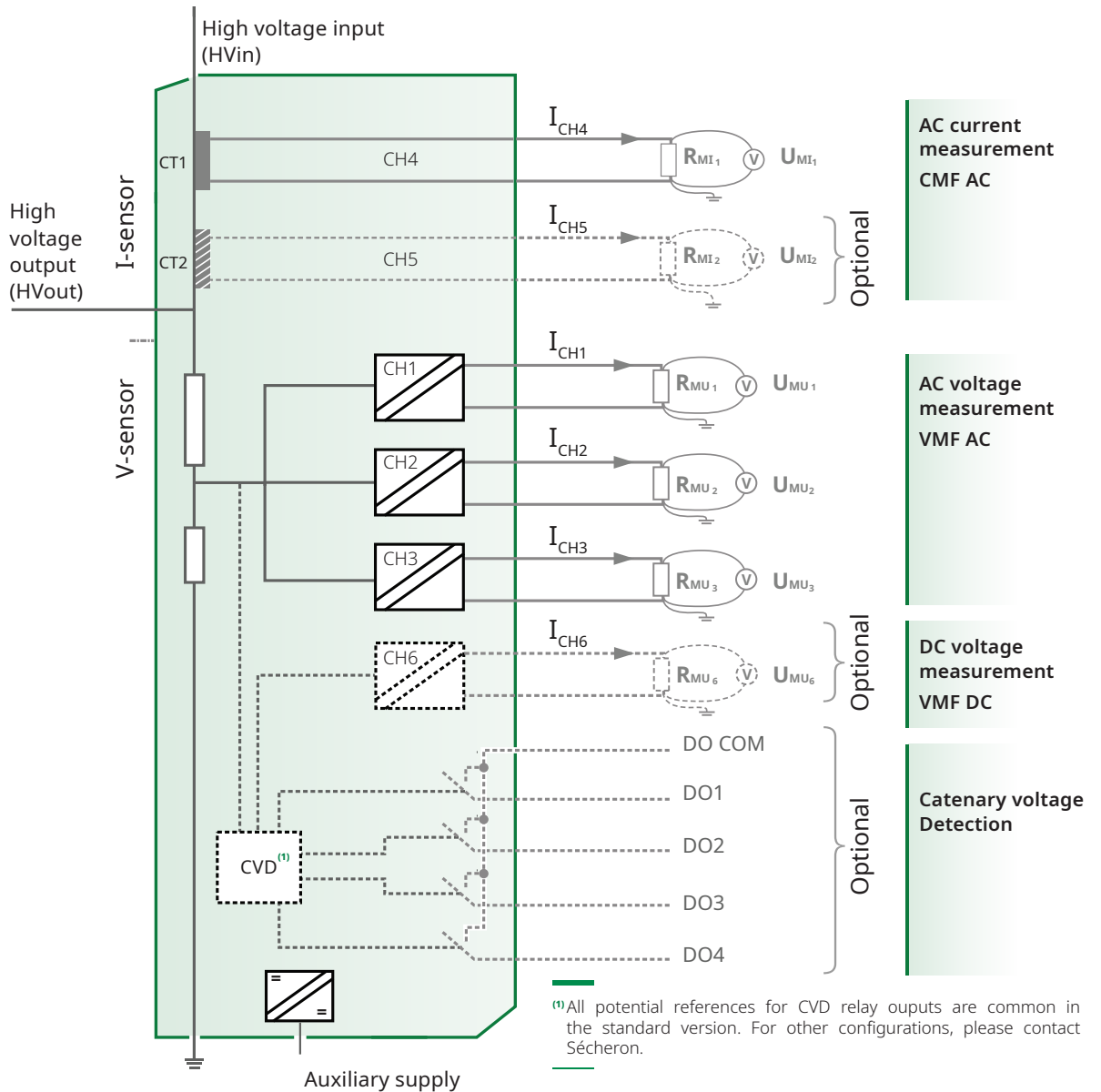

/// TMS A - Voltage measurement

/// TMS B - Voltage & current measurements

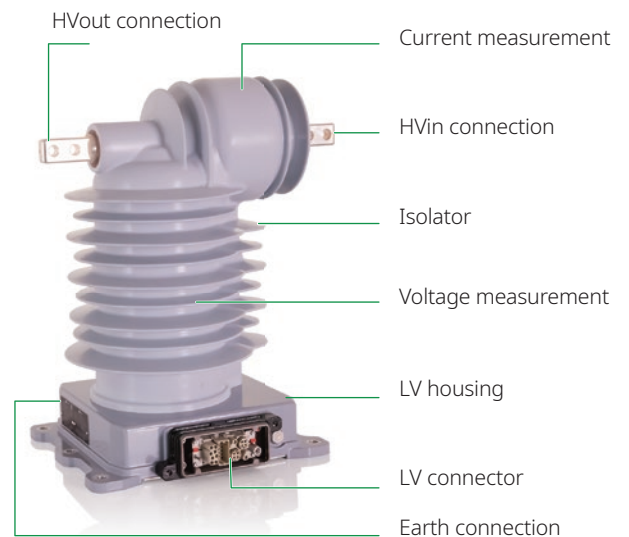
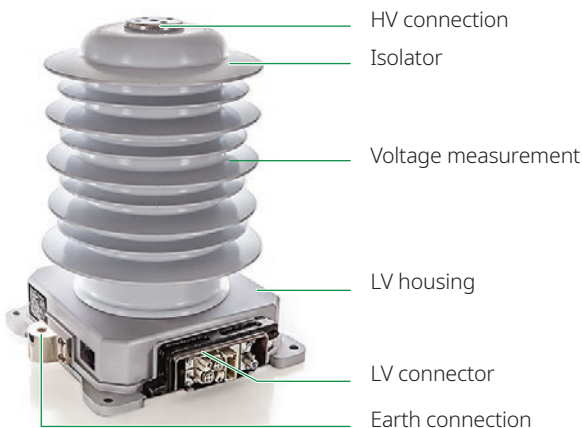

# REPLACING VOLTAGE TRANSFORMER (VT) BY SECHERON TMS

Customers accustomed to use voltage transformer (VT) will find at Sécheron appropriate support to adapt their measurement circuits using Sécheron TMS instead of voltage transformers.

Typical examples of measurement circuits using VT and their equivalent using TMS are shown below. For other circuit configurations, please contact Sécheron.

## One voltage sensor output connected to a single device

### Solutions with VT

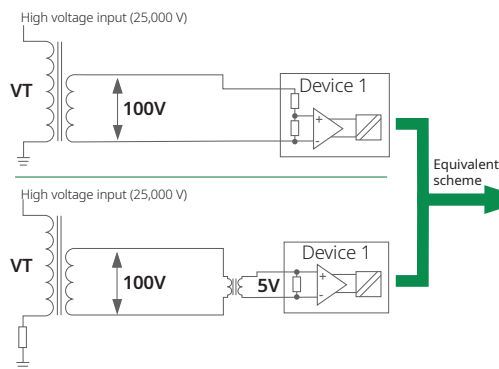

### Solution with TMS

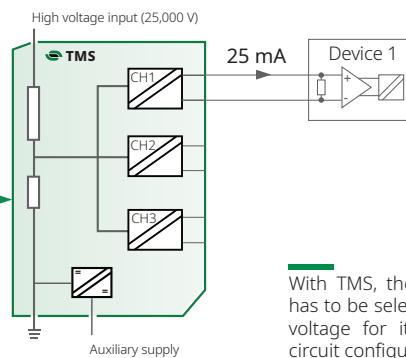

With TMS, the input resistor of Device 1 has to be selected keeping the same input voltage for its electronic circuits as for circuit configuration with VT.

## One voltage sensor output connected to several devices

### Solution with TMS

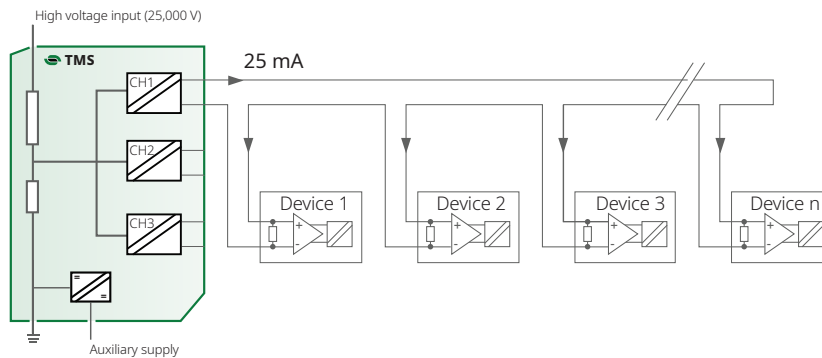

The beside scheme is the most simple and efficient way to supply several consumers (Device 1 to Device n) with one TMS output.

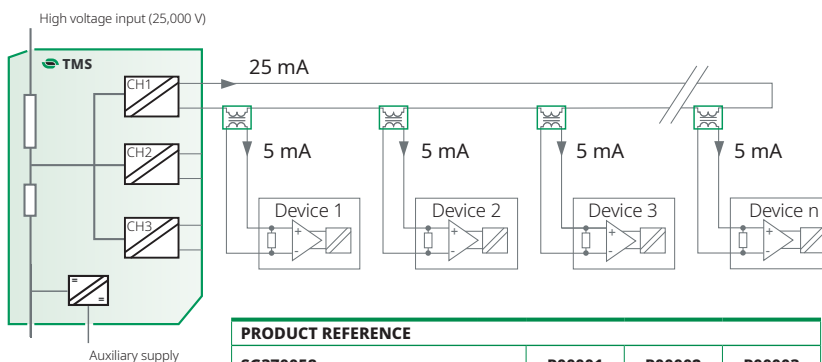

**Individual isolating transformers**

PRODUCT REFERENCE				
SG370058...	P00001	P00002	P00003	
Nominal input current	[mA]	25		
Transformation ratio		5:1 or 1:5	3:1 or 1:3	2:1 or 1:2
Frequency	[Hz]	16.7; 50; 60		
Power frequency voltage	[kV]	1.5		
Dimensions	[mm]	84x63x40		
Installation		Indoor		

If the consumers have to be isolated from each others, Sécheron proposes the following solution with individual isolating transformers for each consumer.

On request, Sécheron can also deliver such isolating transformers.

The value of 5 mA indicated on the scheme is just an example.

# DATA FOR PRODUCT SELECTION

	Symbol	Unit	AC Measurement <sup>(1)</sup>		DC Measurement <sup>(2)</sup>	
			15 kV	25 kV	1.5 kV	3.0 kV
<b>MAIN HIGH VOLTAGE CIRCUIT</b>						
Rated voltage	$U_{n,VMF}$	[kV]	15	25	1.5	3.0
Rated frequencies	$f_n$	[Hz]	16.7	50, 60	DC	
Highest permanent voltage	$U_{max1}$	[V]	17.25	31.5	1.95	4
Highest non-permanent voltage	$U_{max2}$	[V]	19	32	1.95	4.2
Lowest non-permanent voltage	$U_{min2}$	[V]	11	17.5	1.0	2.0
Rated insulation Voltage	$U_{Nm}$	[kV]	31.5		31.5	
Maximum peak measured voltage	$U_{MAX,VMF}$	[kV]	50		2.25	4.5
Rated impulse voltage	$U_{Ni}$	[kV]			170 <sup>(3)</sup>	
Rated power frequency voltage (50Hz/60s)	$U_a$	[kV]			80	
Overvoltage category	OV				4	
Clearance distances		[mm]			≥ 310	
Creepage distances		[mm]	830 (TMS A) / 794 (TMS B)		830 (TMS A) / 794 (TMS B)	
Rated primary current for Current Measurement Function	$I_{n,CMF}$	[A]	100 to 630 <sup>(4)</sup>	60 to 400 <sup>(4)</sup>	Not applicable	
Rated continuous thermal current	$I_{CMF,cth}$	[A]	756 <sup>(4)</sup>		Not applicable	
Rated short-time thermal current (rated short-time current)	$I_{CMF,th}$	[kA/s]	25 / 1 and 40 / 0.1		Not applicable	
Rated dynamic current (rated peak short-time current)	$I_{CMF,dyn}$	[kA]	63		Not applicable	

<sup>(1)</sup> Other rated primary voltages also possible: 12 kV/25 Hz, 12.5 kV/60 Hz. <sup>(2)</sup> Other rated primary voltage also possible: 0.75 kV.

<sup>(3)</sup> Also tested successfully at 185 kV for TMS A. <sup>(4)</sup> For other values, please contact Sécheron.

## LOW VOLTAGE CIRCUITS

### Analog outputs for AC voltage measurement

Number of output			3 insulated outputs		
Current loop output type		[mA]	B (Bipolar) or O (Offset)		
Output current (refer to graphics page 4)		[mA]	Bipolar output type		Offset output type
- DC offset		[mA]	0 ± 0.1		30 ± 0.08
- Factor k (output/input ratio)		[mA/kV]	1		0.4
Measuring resistance	$R_{MU}$	[Ω]	10 to 200		
Maximum peak voltage on measuring resistance		[V]	±10		
Accuracy			Class 0,5 R (EN 50463-2 / IEC 62888-2) & Class 1 (EN/IEC 60044-7)		
Bandwidth at -3 dB		[Hz]	≥ 2,500		
Rated power frequency voltage (50Hz/60s) (against earth and between outputs)	$U_a$	[kV]	1.5		
Fault protection			Protected against short-circuits and open circuits		
Maximum inductance in series with measuring resistance		[mH]	1		
Maximum capacitance in parallel to measuring resistance		[nF]	33		
Reference potential			Outputs shall not float		

### Analog output for DC voltage measurement (combined with CVD function)

Number of outputs			1 insulated output		
Current loop output type		[mA]	B (Bipolar)		
Output current for nominal input voltage		[mA]	20		
0.75 kV			20 mA (in case of single voltage 1.5 kV) / 10 mA (in case of dual voltage 1.5 kV/3. kV)		
1.5 kV			20		
3.0 kV			20		
Measurement resistance	$R_{MU}$	[Ω]	10 to 330		
Maximum peak voltage on measuring resistance		[V]	±10		
Accuracy			Class 0,5 R (EN 50463-2 / IEC 62888-2)		
Bandwidth at -3 dB		[Hz]	≥ 2,000		
Rated power frequency voltage (50Hz/60s) (against earth and between outputs)	$u_a$	[kV]	1.5		
Fault protection			Protected against short-circuits and open circuit		
Maximum inductance in series with $R_{MU}$		[mH]	1		
Maximum capacitance in parallel with $R_{MU}$		[nF]	33		
Reference potential			Output shall not float		

# DATA FOR PRODUCT SELECTION (suite)

	Symbol	Unit	
<b>LOW VOLTAGE CIRCUITS (suite)</b>			
<b>Analog outputs for AC current measurement</b>			
Number of currents outputs			1 or 2 (insulated floating outputs)
Designation			CT1 CT2
Accuracy class			0,5R <sup>(6)</sup> 0,5 <sup>(6)</sup>
			EN 50463-2/IEC 62888-2 EN/IEC 61869-2
Rated transformation ratio ( $I_{n,CMF} / I_{output}$ )	$k_r$		400 <sup>(6)</sup>
Rated resistive burden	$R_b$	[ $\Omega$ ]	2 <sup>(6)</sup>
Burden range		[ $\Omega$ ]	0 to 2 <sup>(6)</sup>
Rated output power, $R_b \times (I_{n,CMF} / k_r)^2$		[VA]	2 (for $I_{n,CMF} = 400$ A) <sup>(6)</sup>
		[VA]	5 (for $I_{n,CMF} = 630$ A) <sup>(6)</sup>
Bandwidth at - 3dB		[kHz]	> 20
Rated power-frequency voltage (50 Hz / 60 s)	$U_a$	[kV]	3
Fault protection			Protected against short-circuits and open circuit
Reference potential			Outputs shall not float
<sup>(6)</sup> For other values, please contact Sécheron.			
<b>Digital outputs for CVD function (Catenary Voltage Detection)</b>			
Number of digital outputs			4 individual relays (Form A)
Minimum switching current		[mA]	1
Rated thermal current		[A]	2
Maximum switching voltage		[V <sub>DC</sub> ]	220
Insulation resistance		[M $\Omega$ ]	> 100
Rated power-frequency withstand voltage to ground (50 Hz)	$U_a$	[V]	1,500
<b>Auxiliary supply</b>			
Auxiliary supply voltage	$U_n$	[V <sub>DC</sub> ]	24 to 110
Auxiliary supply voltage range		[V <sub>DC</sub> ]	0.7 $U_n$ - 1.25 $U_n$
Auxiliary supply power		[W]	<10
Rated power frequency voltage (50 Hz)	$U_a$	[kV]	1.5
<b>Low voltage interface</b>			
Connector type			Harting Han® HPR
<b>OPERATING CONDITIONS</b>			
Installation			Indoor / Outdoor
Altitude		[m]	≤ 2,000
Working ambient temperature	$T_{amb}$	[°C]	-40 to +70
Pollution degree			PD4
Protection Index (low voltage circuit)		[IP]	66 and 67

## ANALOG OUTPUT CONFIGURATION FOR AC VOLTAGE MEASUREMENT

For DC voltage measurement refer to page 12.

### Bipolar type current output

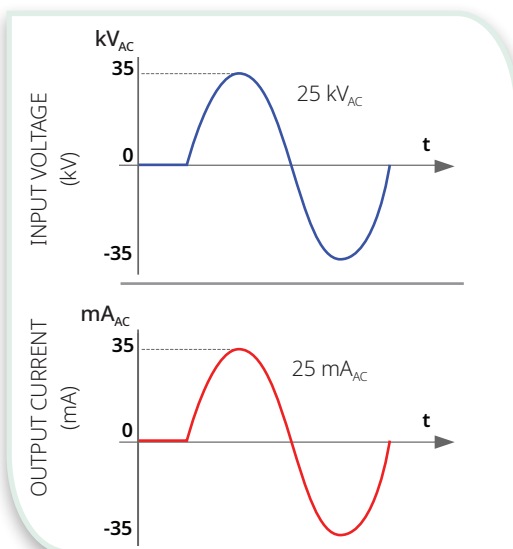

### Offset type current output

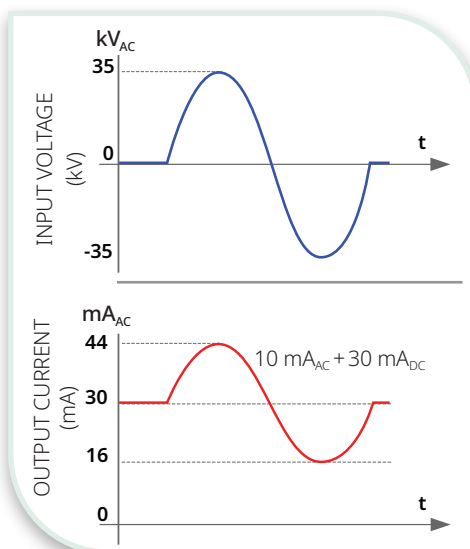

# PRODUCT INTEGRATION

## DIMENSIONS

Dimensions without tolerances are indicative.  
All dimensions are in mm. The maximum allowed flatness deviation of the support frame is 1 mm.

### /// TMS - Voltage measurement (vertical or horizontal installation)

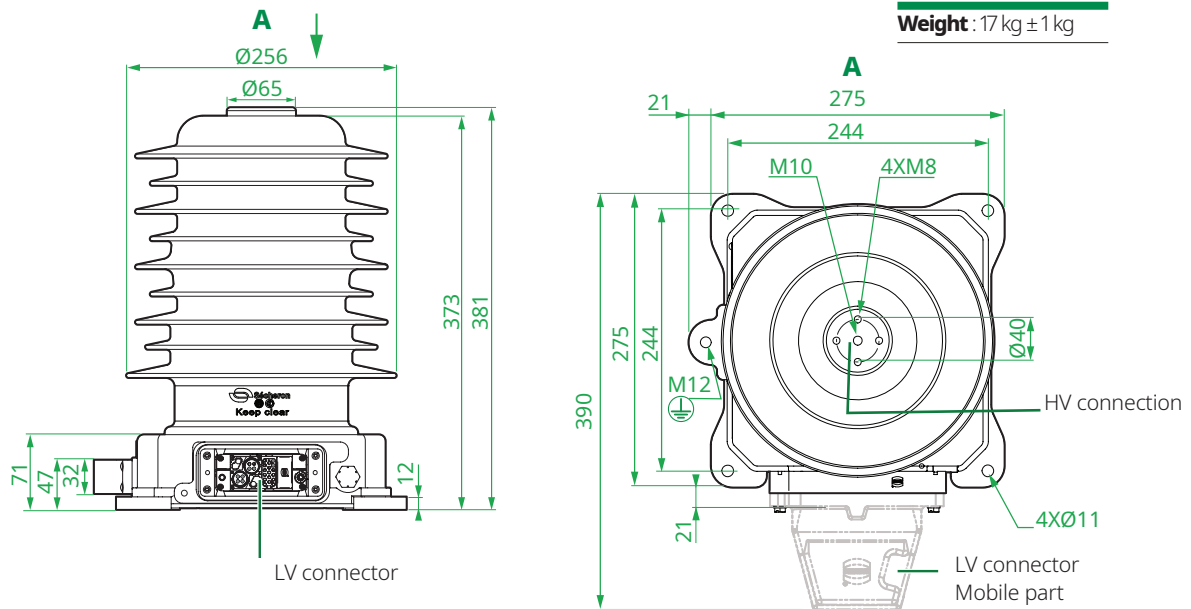

### /// TMS - Voltage & current measurements (vertical or horizontal installation)

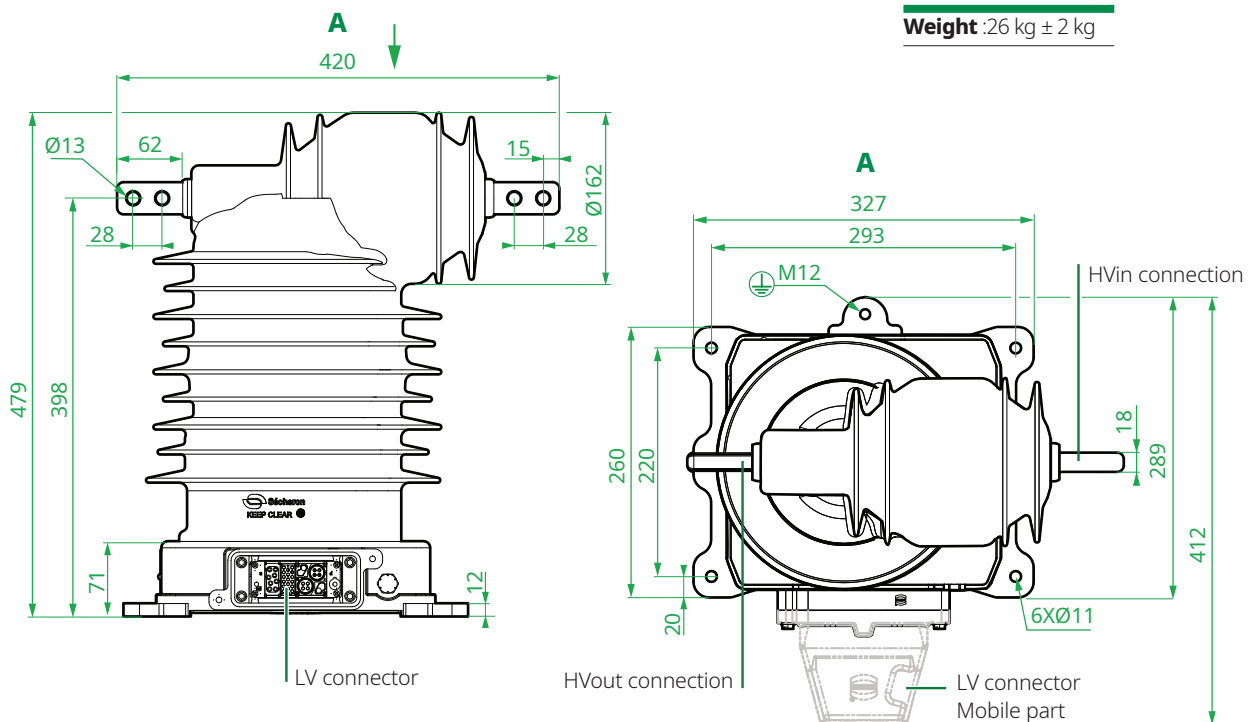



# LOW VOLTAGE WIRING DIAGRAM

(HARTING HAN® CONNECTOR)

## /// TMS - Voltage measurement

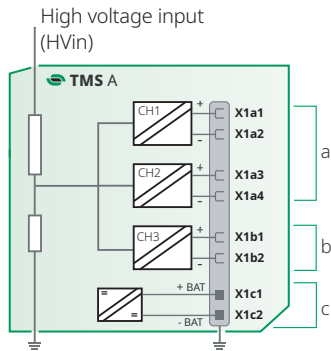

## /// TMS - Voltage & current measurements

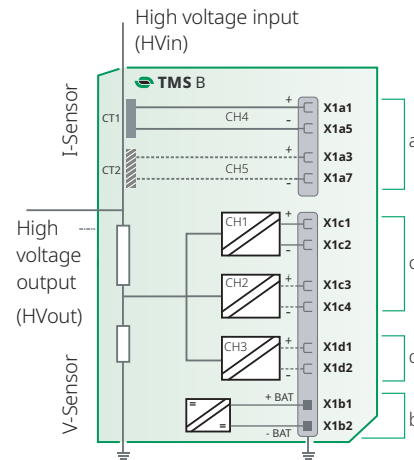

## /// TMS A - Voltage measurement + CVD function

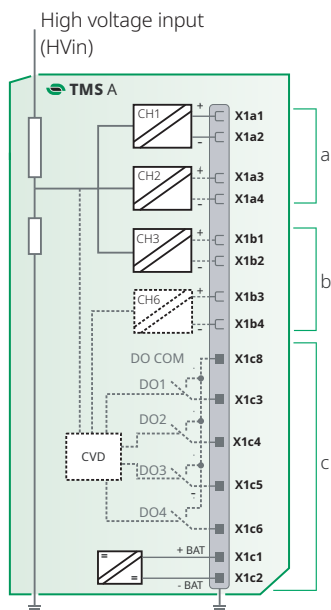



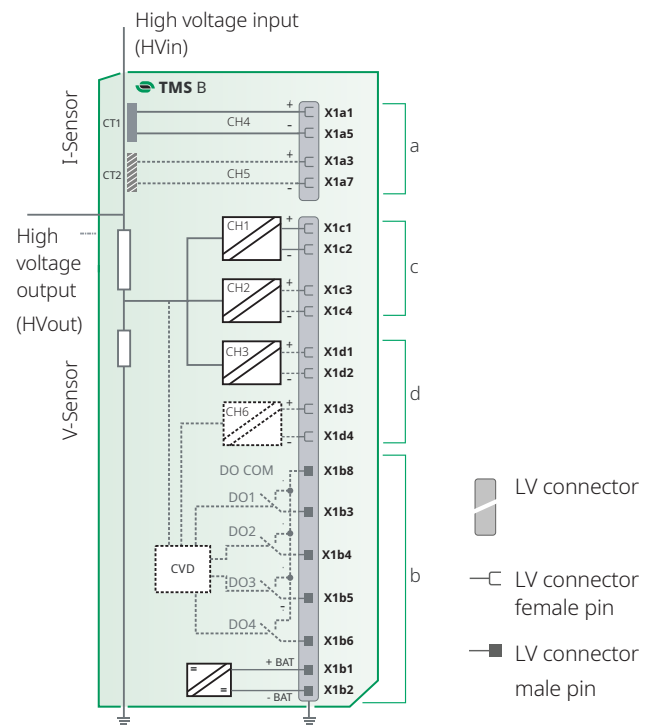



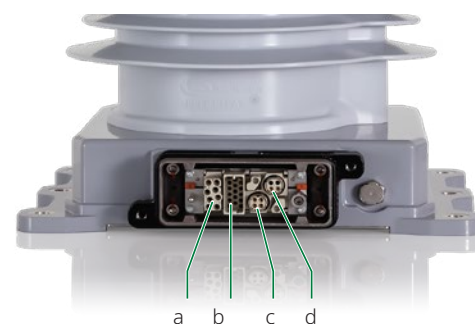

## /// TMS B - Voltage & current measurements + CVD function











- LV connector
- LV connector female pin
- LV connector male pin



## LV MOBILE CONNECTOR (SEPARATELY ORDERED ITEM)

Mobile connector - Kits references for ordering for <b>TMS A (Voltage measurement)</b>										
Type	Number of pin						Cable gland	Cable entry	Sécheron's reference	
	Supply (X1c)	CH1, 2, 3 (X1a, X1b)	CH6 (X1b)	CH4, 5 (Not Applicable)		CVD (X1c)				
	Size 1.5 mm <sup>2</sup>		Size 1.5 mm <sup>2</sup>	Size 2.5 mm <sup>2</sup>	Size 1.5 mm <sup>2</sup>					
Harting Han® HPR 16B	2	6	-	0	0	-	M32	Straight	SG370027R10001	
								Side	SG370027R10002	
							M40	Straight	SG370027R10003	
								Side	SG370027R10004	
Harting Han® HPR 16B	2	6	2	0	0	5	M32	Straight	SG370027R10011	
								Side	SG370027R10012	
							M40	Straight	SG370027R10013	
								Side	SG370027R10014	

Mobile connector - Kits references for ordering for <b>TMS B (Voltage &amp; current measurement)</b>										
Type	Number of pin						Cable gland	Cable entry	Sécheron's reference	
	Supply (X1b)	CH1, 2, 3 (X1c, X1d)	CH6 (X1d)	CH4, 5 (X1a)		CVD (X1b)				
	Size 1.5 mm <sup>2</sup>		Size 1.5 mm <sup>2</sup>	Size 1.5 mm <sup>2</sup>	Size 2.5 mm <sup>2</sup>	Size 1.5 mm <sup>2</sup>				
Harting Han® HPR 16B	2	6	-	4	4	-	M32	Straight	SG370032R10001	
								Side	SG370032R10002	
							M40	Straight	SG370032R10003	
								Side	SG370032R10004	
Harting Han® HPR 16B	2	6	2	4	4	5	M32	Straight	SG370032R10011	
								Side	SG370032R10012	
							M40	Straight	SG370032R10013	
								Side	SG370032R10014	

For CMF output signals, the cable size will depend on the output current that is a function of the primary current value. Therefore the LV connector kit includes 4 pins (2 for CT1 and 2 for CT2) of each section to enable the car builder to select the one suited to its project.

# OPTIONS

(SUBJECT TO ADDITIONAL COSTS)

## CATENARY VOLTAGE DETECTION (CVD)

When this function is selected, the TMS is equipped with an additional module that includes 4 switching relays. The combination of the relay's output signals provides the information related to the line voltage detected by the TMS as shown in the below table.

The thresholds for activation and deactivation of these relays are configurable, as well as their reaction time to get adapted to the projects' needs.

STATE	Description	D01	D02	D03	D04
<b>NO POWER</b>	TMS CVD not supplied	0	0	0	0
<b>NO NETWORK</b>	No valid network recognized	1	1	1	1
<b>15 kV - 16.7 Hz</b> (AC network 1)	15 kV <sub>AC</sub> - 16.7 Hz detected as valid	1	0	0	1
<b>25 kV - 50/60 Hz</b> (AC network 2)	25 kV <sub>AC</sub> - 50 / 60 Hz detected as valid	0	1	1	0
<b>DC 1.5 kV</b> <sup>(1)</sup> (DC network 1)	1.5 kV <sub>DC</sub> system detected as valid	0	0	1	1
<b>DC 3.0 kV</b> (DC network 2)	3 kV <sub>DC</sub> system detected as valid	1	1	0	0

DOx = 0 means relay is OPEN ; DOx = 1 means relay is CLOSED

Any other combination of relay outputs than the one indicated in this table should be considered as a system error.

<sup>(1)</sup> Can also be used to detect DC 0.75 kV in case of dual AC/DC (0.75 kV) vehicle.

### Digital outputs technical data

- ✓ Rated insulation 1.5 kV, 50 Hz
- ✓ Rated thermal current 2 A
- ✓ Min switching current 1 mA
- ✓ Configurable thresholds
- ✓ Configurable switching reaction time
- ✓ In case of detection of 1.5 kV<sub>DC</sub> or 3 kV<sub>DC</sub>, the DC voltage measurement function class 0,5 R (VMF<sub>DC</sub>) and related output are automatically activated, if this function is selected.

### When USA mode is configured

STATE	Description	D01	D02	D03	D04
<b>NO POWER</b>	TMS CVD not supplied	0	0	0	0
<b>NO NETWORK</b>	No valid network recognized	1	1	1	1
<b>12 kV - 25 Hz</b> (AC network 1)	12 kV <sub>AC</sub> - 25 Hz detected as valid	1	0	0	1
<b>12.5 kV - 60 Hz</b> (AC network 2)	12.5 kV <sub>AC</sub> - 60 Hz detected as valid	1	1	0	0
<b>25 kV - 60 Hz</b> (AC network 3)	25 kV <sub>AC</sub> - 60 Hz detected as valid	0	1	1	0
<b>DC 0.75 kV</b> (DC network 1)	0.75 kV <sub>DC</sub> - system detected as valid	0	0	1	1

DOx = 0 means relay is OPEN ; DOx = 1 means relay is CLOSED

Any other combination of relay outputs than the one indicated in this table should be considered as a system error.

### Relays activation and deactivation thresholds for AC voltage detection

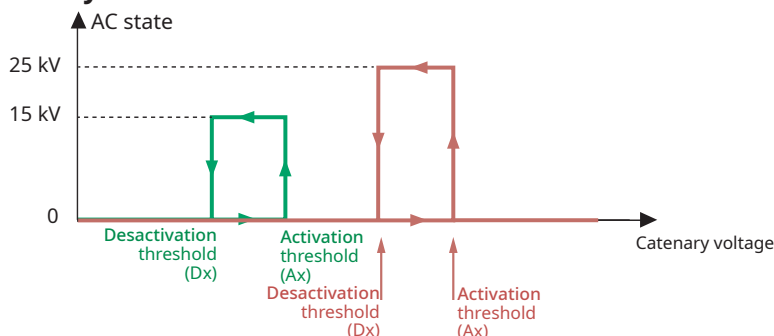

For AC voltage, both the voltage and frequency are detected.

Network nominal voltage	Activation threshold "Ax"	Deactivation threshold "Dx"	Measurement duration before activation/deactivation of relays
	Ax selection range [kV]	Dx selection range [kV]	Selection range T <sub>Ax</sub> , T <sub>Dx</sub> [ms]
<b>15 kV (16.7 Hz)</b>	7 to 12	(0.75 to 0.98)*Ax	500 to 3,000
<b>25 kV (50/60 Hz)</b>	12 to 19		
<b>12/12.5 kV (25/60 Hz)</b>	7 to 12		

### Digital outputs technical data

- ✓ AC threshold accuracy 500 V (over the entire temperature range)
- ✓ Activation/deactivation time calibrated at network nominal voltage

## Relays activation and deactivation thresholds for DC voltage detection

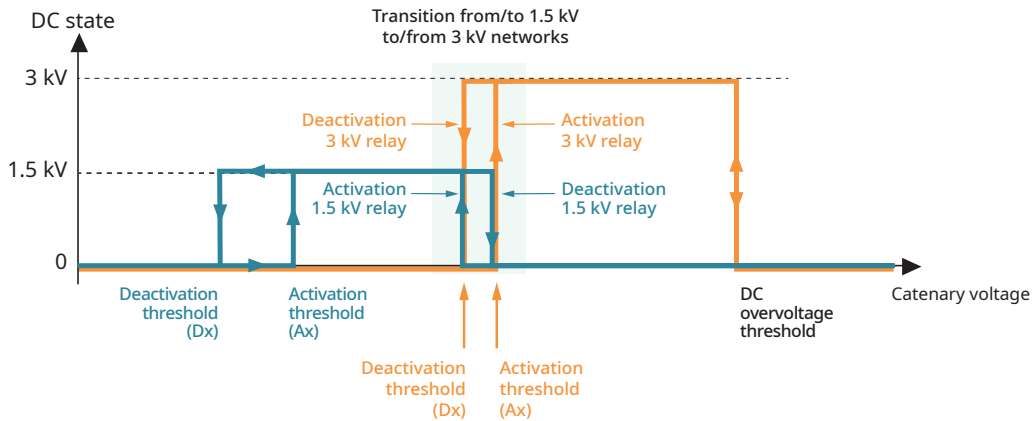

Network nominal voltage	Activation threshold "Ax"	Relay activation threshold "Dx"	Measurement duration before activation/deactivation of relays selection Range $T_{Ax}, T_{Dx}$ [ms]
	Ax selection Range [kV]	Dx selection Range [kV]	
0.75 kV <sub>DC</sub>	0.4 to 1.0	(0.75 to 0.98)xAx	500 to 3,000
1.5 kV <sub>DC</sub>	0.4 to 1.0		
3.0 kV <sub>DC</sub>	1.8 to 2.3	(0.75 to 0.99)xAx	

### Digital outputs technical data

- ✓ DC threshold accuracy 50V (over the entire temperature range)
- ✓ Activation/deactivation time calibrated at network nominal voltage

## DC VOLTAGE MEASUREMENT CLASS 0,5 R (VMF<sub>DC</sub>)

This function can be selected only if the previous Catenary Voltage Detection function (CVD) has been selected. This function is intended for energy measurement and complies to the requirements of standards EN 50463-2 / IEC 62888-2.

Because of its specific assignment, this signal is only provided as bipolar output type.

The DC voltage measurement function is activated only in case a DC line voltage is detected by the CVD function.

**Single DC voltage vehicle**  
1.5 kV network configuration

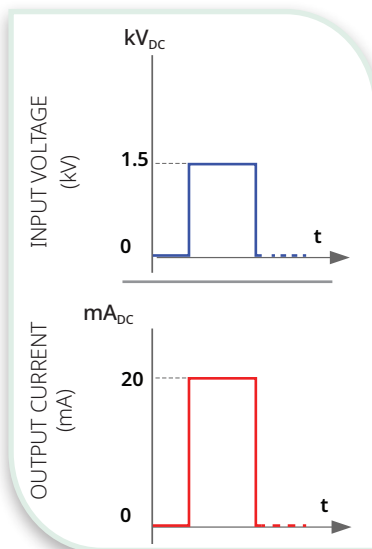

**Single DC voltage vehicle**  
3 kV network configuration

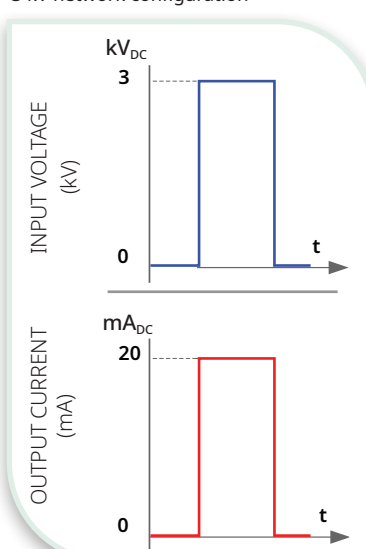

**Dual DC voltage vehicle**  
1.5 & 3 kV network configuration

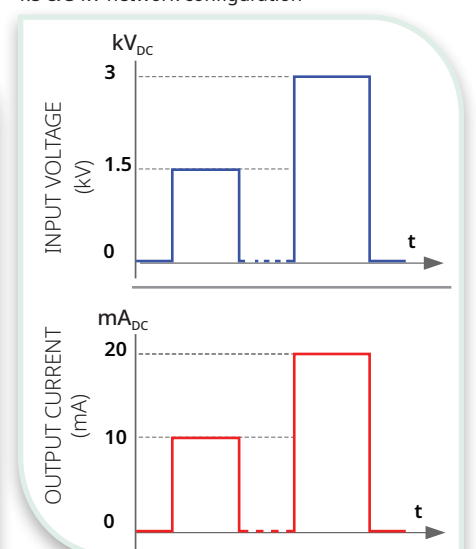

# INTEGRATION OF TMS IN SECHERON AC HIGH VOLTAGE SYSTEMS

## AC MODFRAME

The **AC MODFRAME** is an integrated solution developed for open-air rooftop installation on AC and AC/DC Electrical Multiple Units (EMU). It integrates most of the high voltage roof components required for the operation and protection of AC rail vehicles on a single outdoor frame. The main components installed are from Sécheron's range, supplemented by other devices from leading third party suppliers. All components installed on the MODFRAME are

connected together with busbars, cables and braids, offering the car builder a simple and easy interface for high voltage connections between the MODFRAME and the vehicle. Low voltage cables are directly connected to the individual components through easily accessible outdoor type low voltage connectors. The installation of the MODFRAME on the roof does not require any roof cut-out except if the manual operation is selected for the earthing device.

### Typical applications

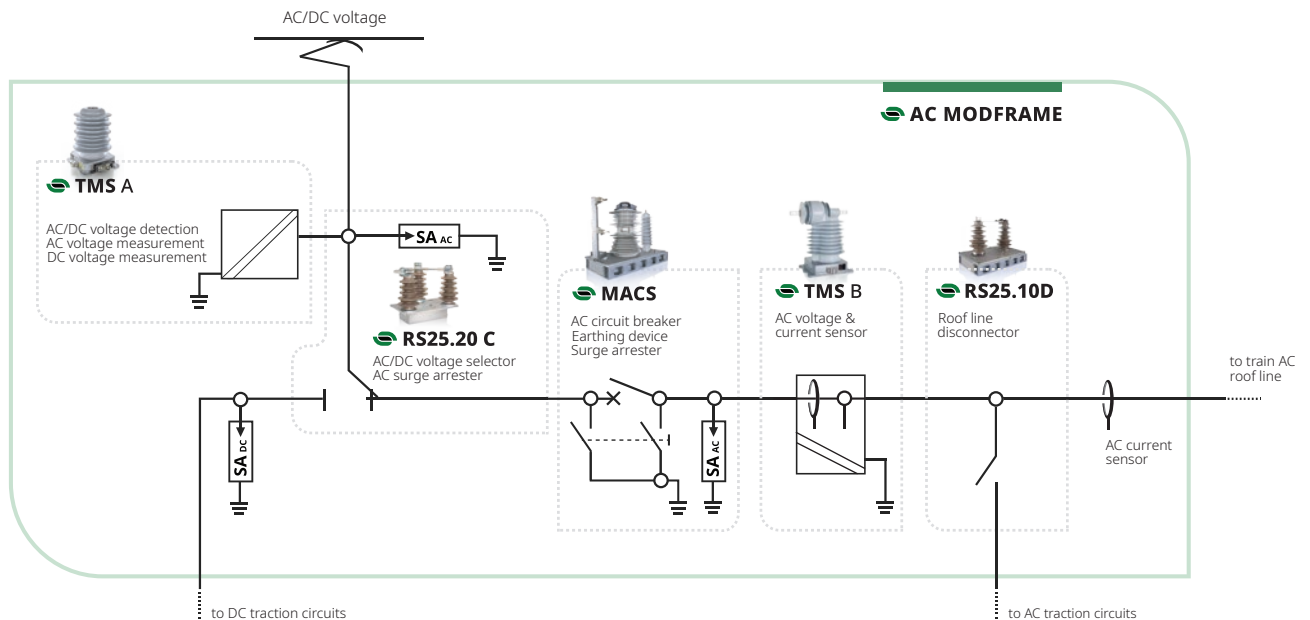

### AC MODFRAME

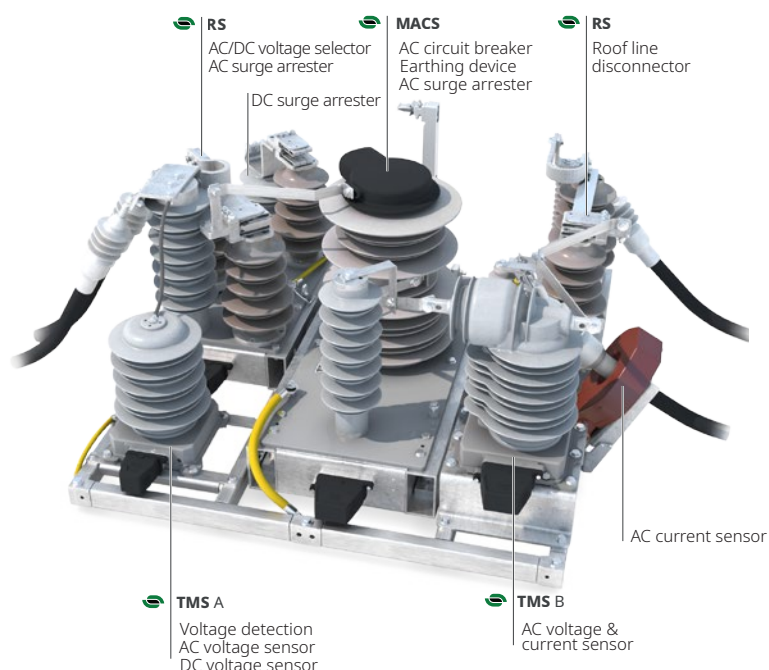

## AC MODBOX®

Car builders looking for solutions to protect roof-mounted high-voltage equipment from harsh environmental conditions, or wishing to reduce the aerodynamic drag of vehicles on their high-speed train platforms consider our **AC MODBOX®**.

The Sécheron AC MODBOX® compact metal enclosure ensures a safe and efficient integration of our AC circuit breakers and various high- and low-voltage components, among which the voltage sensor type TMS. AC MODBOX can also be installed inside the vehicle or under its chassis.

### Typical applications

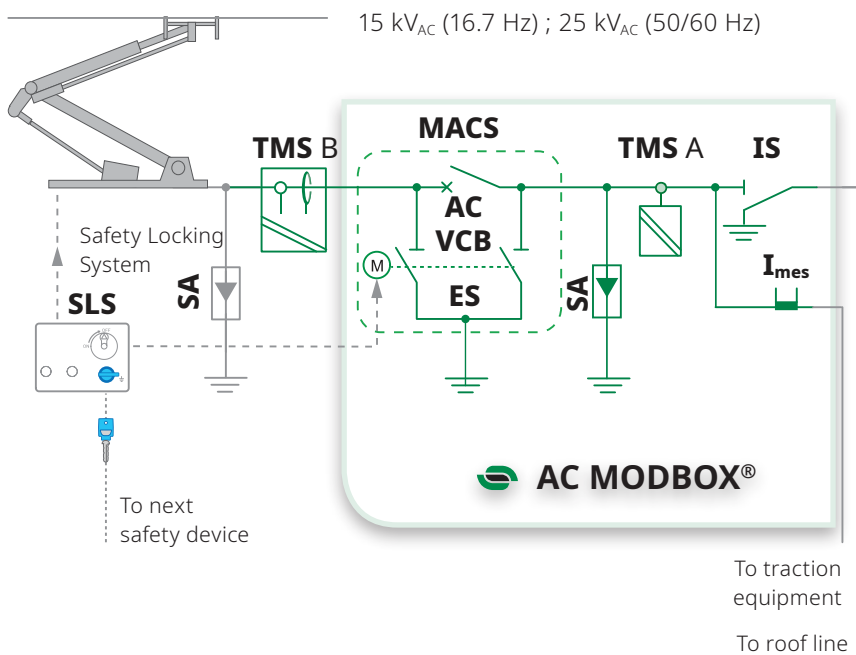

- SLS** : Safety Locking System
- SA** : Surge arrester
- TMS A** : AC voltage measurement
- TMS B** : AC voltage measurement & current sensor
- MACS** : Main AC switch
- AC VCB** : AC vacuum circuit breaker (MACS)
- ES** : Earthing device (MACS)
- IS** : Disconnect switch

### COMPONENTS FOR AC VEHICLES

### REFERENCE BROCHURES

#### HIGH VOLTAGE INTEGRATED SYSTEM



#### AC MODFRAME

SA016148BEN



#### AC MODBOX®

SG580044BEN

#### OFFLOAD SWITCHES



#### RS

SP1870125BEN



#### XMS

SG200998BEN



#### BTE

SP1880136BEN

#### AC CIRCUIT BREAKER



#### MACS

SG325101BEN

#### CONTACTORS



#### BMS..08-10

SG202168BEN



#### BMS..15-18

SG202454BEN



#### BSV\_SLS

SP1880129BEN



#### KM-DL

SA004770BEN



#### BMS..08 FOR PMSM MOTOR

SA003724BEN



#### BMS 36.10

SA015795BEN

# DESIGNATION CODE FOR ORDERING

- Be sure to establish the designation code from the latest version of our brochure by downloading it from the website: www.secheron.com
- Be careful to write down the complete alphanumeric designation code with 12 characters when placing your order.
- For technical reasons some variants and options indicated in the designation code might not be combined.
- For other configurations not described in the brochure, please contact Secheron.
- The bold characters of the designation code define the device type.

<b>Example of customer's choice:</b>	<b>TMS</b>	<b>B</b>	<b>2</b>	<b>Z</b>	<b>E</b>	<b>1</b>	<b>01</b>	<b>ZZ</b>	<b>2</b>
Line:	10	11	12	13	14	15	16	17	18

## DESIGNATION CODE

<sup>(\*)</sup> Options are subject to additional costs

Line	Description	Designation	standard	Options*	Customer's choice
10	Product type	Traction Measurement - TMS	<b>TMS</b>		<b>TMS</b>
11	Configuration	Voltage sensor Voltage & current sensor	A B		
12	AC input voltage for measurement function (class 0,5 R)	25 kV / 50-60 Hz & 15 kV / 16.7 Hz 25 kV / 50 Hz 25 kV / 60 Hz 15 kV / 16.7 Hz 25 kV / 50 Hz & 15 kV / 16.7 Hz 25 kV / 50-60 Hz 12 kV / 25 Hz; 12.5 kV / 60 Hz; 25 kV / 60 Hz	2 3 4	1    6 7 A	
13	DC input voltage for measurement function (class 0,5 R) - In case "2" is selected line 18 For other selection than "2" line 18 - Not Applicable	1.5 kV 3.0 kV Dual DC voltage 1.5 kV and 3.0 kV 0.75 kV	Z	1 2 3 4	
14	Voltage Measurement Function - output configuration Single or dual AC voltage	1B (Bipolar) <sup>(1)</sup> 1B (Bipolar) + 2O (Offset) 2B (Bipolar) + 1O (Offset) 3B 3O	E A	B C D	
15	Low Voltage connector type	Harting Han® HPR	1		
16	Current Measurement Function CT1 <sup>(2) (3)</sup> Class 0,5 or 0,5 R   I <sub>n,CMF</sub> : 60-400 A at 25 kV/50-60 Hz   I <sub>n,CMF</sub> = 100-630 A at 15 kV/16.7 Hz Other characteristics <sup>(4)</sup>	Not Applicable	ZZ 01		
17	Current Measurement Function CT2 <sup>(2) (3)</sup> Class 0,5 or 0,5 R   I <sub>n,CMF</sub> : 60-400 A at 25 kV/50-60 Hz   I <sub>n,CMF</sub> = 100-630 A at 15 kV/16.7 Hz Other characteristics <sup>(4)</sup>	Not Applicable	ZZ 01		
18	Integrated Catenary Voltage Detection (CVD)	Not Applicable Yes - Multisystem AC <sup>(5)</sup> Yes - Multisystem AC & DC <sup>(5)</sup>	Z	1 2	

<sup>(1)</sup> Only for TMS (voltage & current sensor) with one current measurement (CT1 - Code 01 digit 16) and class 0,5 R. • <sup>(2)</sup> Current measurement function only possible if "Voltage & current sensor" selected line 11. • <sup>(3)</sup> The nominal current value within the selected range must be indicated on the next page for the test calibration purpose. • <sup>(4)</sup> In case "other characteristics" is selected, please define precisely the requirements for each CT: applicable standards, accuracy class, frequencies, nominal current, rated burden and other important characteristics. • <sup>(5)</sup> Activation and deactivation data to be indicated at the following page, if the catenary voltage detection function is selected.

### Mobile connector kit to be ordered separately refer to page 10:

- TMS A (without CVD):  SG370027R10002      TMS A (with CVD):  SG370027R10012      Other references:  SG370027R100\_\_  
 - TMS B (without CVD):  SG370032R10002      TMS B (with CVD):  SG370032R10012      Other references:  SG370032R100\_\_

### Optional isolating transformers for TMS voltage outputs according to page 5:

- Ratio 5:1 or 1:5:  SG370058P00001      Ratio 3:1 or 1:3:  SG370058P00002      Ratio 2:1 or 1:2:  SG370058P00003

# DESIGNATION CODE FOR ORDERING (SUITE)

## Accuracy class & nominal current value for CT1, CT2

(relates to note <sup>(9)</sup> of the designation code table page 15)

### Data for CT1 (if line 16 is selected)

Accuracy class:  0,5 R  0,5  
\_\_\_\_ A @ \_\_\_\_ Hz  
\_\_\_\_ A @ \_\_\_\_ Hz (second value in case multisystem application is selected line 12)

### Data for CT2 (if line 17 is selected)

Accuracy class:  0,5 R  0,5  
\_\_\_\_ A @ \_\_\_\_ Hz  
\_\_\_\_ A @ \_\_\_\_ Hz (second value in case multisystem application is selected line 12)

## Settings for catenary voltage detection

(relates to note <sup>(9)</sup> of the designation code table page 15, if this function is selected)

### Activation thresholds (Ax), Deactivation thresholds (Dx) and times before activation/deactivation

(For selection range refer to info page 11-12)

Please indicate the threshold settings required for voltage detection of your project vehicles, for each of the AC and/or DC networks on which these vehicles will operate. If there is no particular customer's requirement for the activation threshold, Sécheron recommends this value to be  $\leq$  to 80% of the minimum network voltage.

### All world railway networks except US market

AC network 1 -  $f_n$  : 16.7 Hz      AC network 2 -  $f_n$  : \_\_\_\_ Hz (50 or 60 Hz)  
Threshold "A<sub>1</sub>" \_\_\_\_ kV      Threshold "A<sub>2</sub>" \_\_\_\_ kV  
Threshold "D<sub>1</sub>" \_\_\_\_ kV      Threshold "D<sub>2</sub>" \_\_\_\_ kV

DC network 1 - \_\_\_\_ kV (1.5 or 0.75 kV)      DC network 2 - 3 kV  
Threshold "A<sub>3</sub>" \_\_\_\_ kV      Threshold "A<sub>4</sub>" \_\_\_\_ kV  
Threshold "D<sub>3</sub>" \_\_\_\_ kV      Threshold "D<sub>4</sub>" \_\_\_\_ kV

### Required times for relays activation and deactivation

T<sub>A</sub> before activation \_\_\_\_ ms  
T<sub>D</sub> before deactivation \_\_\_\_ ms

### Specific US networks

AC network 1 : 12 kV - 25 kV      AC network 2 : 12.5 kV - 60 Hz  
Threshold "A<sub>1</sub>" \_\_\_\_ kV      Threshold "A<sub>2</sub>" \_\_\_\_ kV  
Threshold "D<sub>1</sub>" \_\_\_\_ kV      Threshold "D<sub>2</sub>" \_\_\_\_ kV

AC network 3 : 25 kV - 60 Hz      DC network 1 - 0.75 kV  
Threshold "A<sub>3</sub>" \_\_\_\_ kV      Threshold "A<sub>4</sub>" \_\_\_\_ kV  
Threshold "D<sub>3</sub>" \_\_\_\_ kV      Threshold "D<sub>4</sub>" \_\_\_\_ kV

### Required times for relays activation and deactivation

T<sub>A</sub> before activation \_\_\_\_ ms  
T<sub>D</sub> before deactivation \_\_\_\_ ms



📍 Sécheron SA  
Rue du Pré-Bouvier 25  
1242 Satigny - Geneva  
CH-Switzerland

[www.secheron.com](http://www.secheron.com)  
Tel: +41 22 739 41 11  
Fax: +41 22 739 48 11  
ess@secheron.com

Signature:

Name:

Place and date: